

MODEL 276B3

3-Phase Current Transformers

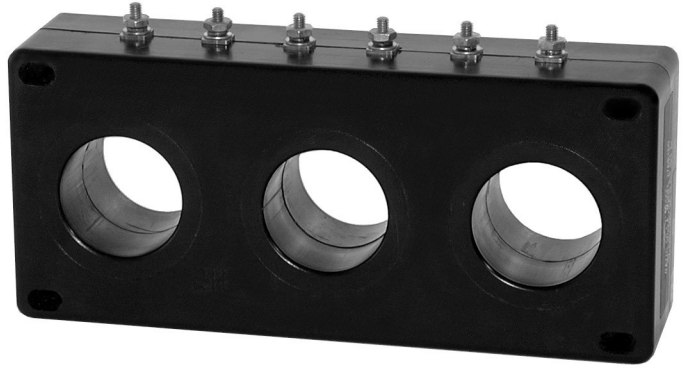

- Monitor 3-phase currents from 50-1200 amps
- 25 - 400Hz
- Brass stud secondary terminals
- Agency approved

DESCRIPTION

The Model 276B3 Current Transformer is a ring-type 3-phase current transformer (CT) for currents from 50 to 1200 amps. The Model 276B3 has an accuracy rating of $\pm 2\%$ for 50-100 amp CT's and $\pm 1\%$ over 100 amps at 60Hz. This CT also features a 25-400Hz frequency range and #8-32 brass secondary terminals. Polarity markings are stamped on the transformer. The Model 276B3 is UL Recognized and CSA Certified.

SPECIFICATIONS

Part No.	Ratio	Max VA for 1% accuracy	Secondary Winding Resistance at 167° F
276B3-50	50:5	2.5	.0153
276B3-100	100:5	2.5	.0306
276B3-150	150:5	7.5	.0459
276B3-200	200:5	10	.0612
276B3-250	250:5	12	.0765
276B3-300	300:5	20	.0919
276B3-400	400:5	25	.122
276B3-500	500:5	5	.0643
276B3-600	600:5	10	.0771
276B3-750	750:5	15	.0964
276B3-800	800:5	15	.1030
276B3-1000	1000:5	20	.1290
276B3-1200	1200:5	25	.1540

DIMENSIONS: 50 - 400 Amps

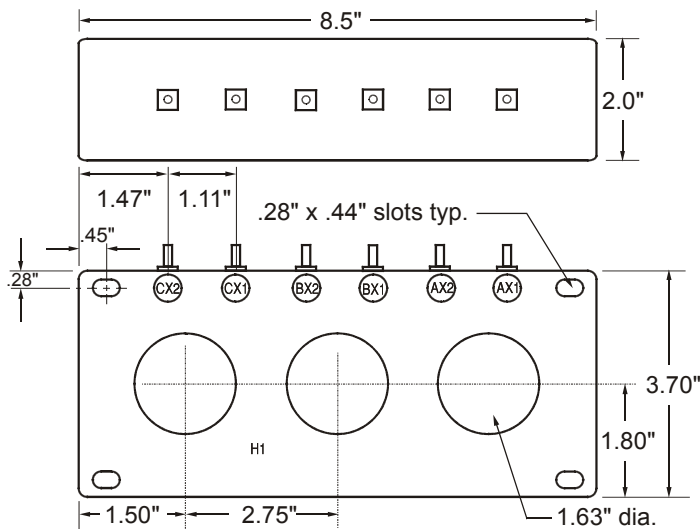

DIMENSIONS: 500 - 1200 Amps

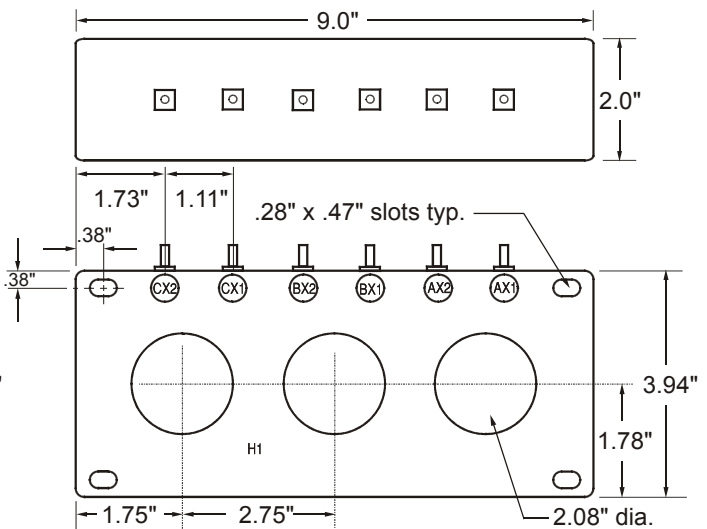

TIME MARK
CORPORATION

11/2011
© 2011 TIME MARK CORPORATION

TIME MARK is a division of  AEMT, Inc.

MODEL 276B3 3-Phase Current Transformer

READ ALL INSTRUCTIONS BEFORE INSTALLING, OPERATING OR SERVICING THIS DEVICE.
KEEP THIS DATA SHEET FOR FUTURE REFERENCE.

GENERAL SAFETY

POTENTIALLY HAZARDOUS VOLTAGES ARE PRESENT AT THE TERMINALS OF THE MODEL 276B3.
ALL ELECTRICAL POWER SHOULD BE REMOVED WHEN CONNECTING OR DISCONNECTING WIRING.
THIS DEVICE SHOULD BE INSTALLED AND SERVICED BY QUALIFIED PERSONNEL.

Installation Instructions

Primary Turn Ratio Modification

The nameplate of the current transformer is based on the condition of that the primary conductor will be passed once through the transformer window. This rating can be reduced in even multiples by looping the conductor two or more times through the window. A transformer having a rating of 200 to 5 amps will be changed to 50 to 5 amps if four loops or turns are made with the primary cable as illustrated.

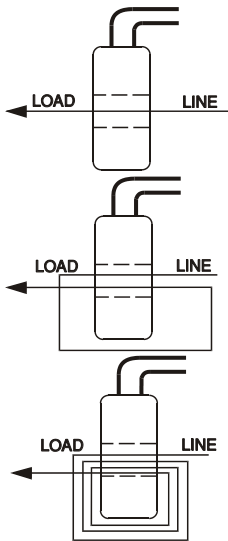

1 Primary Turn			
Nameplate Ratio	Actual Ratio	Nameplate Ratio	Actual Ratio
100:5	100:5	400:5	400:5
150:5	150:5	500:5	500:5
200:5	200:5	600:5	600:5
300:5	300:5	800:5	800:5

2 Primary Turns			
Nameplate Ratio	Actual Ratio	Nameplate Ratio	Actual Ratio
100:5	50:5	400:5	200:5
150:5	75:5	500:5	250:5
200:5	100:5	600:5	300:5
300:5	150:5	800:5	400:5

4 Primary Turns			
Nameplate Ratio	Actual Ratio	Nameplate Ratio	Actual Ratio
100:5	25:5	400:5	100:5
150:5	37.5:5	500:5	125:5
200:5	50:5	600:5	150:5
300:5	75:5	800:5	200:5

The ratio of the current transformer can be modified by altering the number of secondary turns by forward or back-winding the secondary lead through the window of the CT.

By adding secondary turns the same primary amperage will result in a decrease in secondary output. By subtracting secondary turns the same primary amperage will result in greater secondary output.

Again using the 300:5 example, adding 5 secondary turns will require 325 amps on the primary to maintain the 5 amp secondary output, or

$$\frac{325p}{5s} = \frac{65s}{1p}$$

Deducting 5 secondary turns will only require 275 amps on the primary to maintain the 5 amp secondary output, or

$$\frac{275p}{5s} = \frac{55s}{1p}$$

The above ratio modifications are achieved in the following manner.

- To add secondary turns, the white lead should be wound through the CT from the side opposite the polarity mark.
- To subtract secondary turns, the white lead should be wound through the CT from the same side as the polarity mark.

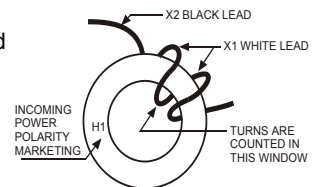
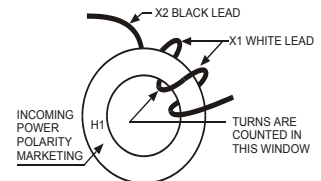

Secondary Turn Ratio Modification

Formula:

$$\frac{I_p}{I_s} = \frac{N_s}{N_p}$$

Where:

I_p - Primary amperage
 I_s - Secondary amperage
 N_p - Number of primary turns
 N_s - Number of secondary turns

Example:

A 300:5 current transformer

$$\frac{300p}{5s} = \frac{60s}{1p}$$

(in practicality, one turn is dropped from the secondary as a ratio correction factor).

TROUBLESHOOTING

Should this unit fail to operate properly, contact the manufacturer at **800-862-2875**.

WARRANTY

This product is warranted to be free from defects in materials and workmanship for one year. Should this device fail to operate, we will repair it for one year from the date of manufacture. For complete warranty details, see the *Terms and Conditions of Sales* page in the front section of the Time Mark catalog or contact Time Mark at 1-800-862-2875.



TIME MARK
CORPORATION

11/2011

© 2011 TIME MARK CORPORATION

TIME MARK is a division of  AEMT, Inc.